



The NOVA 2U dual display console drawer is designed for Command and Control Systems which demand quick deployment of side by side displays.

2U 22" deep platform allows small size and transit case portability. To ensure chassis ruggedness, mobility and quality, as well as for harsh environment applications, the NOVA drawer is meticulously constructed.

This NOVA Series offers diverse options on monitors with different resolutions and brightness, which include 17" 4K, 17" Full HD , High Bright 17" Full HD and 4:3 19" industrial grade LCD. The solid 104-key keyboard is integrated with either touch pad or trackball.

Key Benefits

- ▶ 2U 22" short depth design
- ▶ Rugged construction for mobility & durability
- ▶ Built-in solid bearing slide rails
- ▶ Built-in dual stereo speaker (per display)
- ▶ Three LED backlit display selections (4K, HD, 4:3)
- ▶ DVI-D + VGA video input for HD & 4:3 (per display)
- ▶ Display port 1.2 video input for 4K (per display)
- ▶ 104-key keyboard with either touchpad or trackball (Combo PS2 / USB)
- ▶ Fits 24" ~ 36" rack via adjustable mounting brackets

Options

- 17" 4K, 17" HD , High Bright 17" HD or 4:3 19" LCD
- DC power : 24V / 48V / 110V / 125V / 250V
- 3G / HD / SD-SDI Broadcast-grade input
- Sunlight readable 17" HD display
- MAC or SUN Micro keyboard
- Touchscreen : Projected Capacitive (10-pt) or Resistive (1-pt)
- Front USB hub port for device access

Models



L mounted



R mounted

4K 17" Display

3840 x 2160 native resolution / Display port 1.2 video input
1920 x 1080 & 1920 x 1200 resolution support

LCD2U17-2K-02L : Dual display console drawer (L mounted)

LCD2U17-2K-02R : Dual display console drawer (R mounted)

19" 4:3 Display

1280 x 1024 native resolution / DVI-D + VGA video input

LCD2U19-2T-02L : Dual display console drawer (L mounted)

LCD2U19-2T-02R : Dual display console drawer (R mounted)

HD 17" Display

1920 x 1080 native resolution / DVI-D + VGA video input

LCD2U17-2H-02L : Dual display console drawer (L mounted)

LCD2U17-2H-02R : Dual display console drawer (R mounted)

HD 17" High Bright Display

1920 x 1080 native resolution / DVI-D + VGA video input

LCD2U17-2H-03L : Dual display console drawer (L mounted)

LCD2U17-2H-03R : Dual display console drawer (R mounted)

Nova 2U Rack Mount Dual Monitor KVM Console Drawer

Product Specifications

LCD Panel	LCD2U17-2K-02	LCD2U17-2H-02	LCD2U19-2T-02
Native resolution	3840 x 2160	1920 x 1080	1280 x 1024
Panel size (diagonal)	17.3"	17.3"	19"
Brightness (cd/m ²)	400	400	250
Contrast ratio (typ.)	1000 : 1	600 : 1	1000 : 1
Colors	16.7 M, 8-bit	16.7 M, 8-bit	16.7 M
Viewing angle (L/R/U/D)	89/89/89/89	80/80/60/80	85/85/80/80
Response time (ms)	Max. 30	40	5
Dot pitch (mm)	0.0995	0.1989	0.294
Display area (mm)	382.12H x 214.94V	381.888H x 214.812V	337.92H x 270.33V
Surface treatment	Anti-glare	Anti-glare, Hard-coating	Haze 25%, Hard-coating
Surface hardness	3H	3H	3H
Backlight type	LED	LED	LED
MTBF (hrs)	20,000	50,000	30,000

* For High Bright 17" HD display spec, please contact us for details.

Video			
Digital	Display port	DP 1.2 / HDCP 1.3	-
	DVI-D	-	DVI-D, TMDS single link
Analog	VGA	-	Analog 0.7Vp-p
	Plug & Play	DVI / VGA	VESA EDID structure 1.3
Synchronization	VGA	-	Separate, Composite & SOG

Power				
Input		Auto-sensing 100 to 240VAC, 50 / 60Hz		
Consumption	Screen on	Max. 29W	Max. 25W	Max. 25W
	Power saving	Max. 9W	Max. 4W	Max. 4W
	Power button on	Max. 2W	Max. 1W	Max. 1W

Physical		
Product (W x D x H)	mm	441.6 x 550 x 88
	inch	17.4 x 21.7 x 3.5
Packing (W x D x H)	mm	585 x 620 x 190
	inch	23 x 24.4 x 7.5
Weight	Net	Dual display
	Gross	Dual display
		23.4 kg / 51.5 lb
		28.4 kg / 62.5 lb
Chassis color		Black
Chassis materials		Steel

Compliance	
EMC	FCC & CE certified
Safety	CE / LVD certified
Environment	RoHS2 & REACH compliant

Environment	
Operating temp.	0 to 55°C degree
Storage temp.	-20 to 60°C degree
Operating humidity	20~90%, non-condensing
Storage humidity	5 ~90%, non-condensing
Operating altitude	16,000 ft
Non-operating altitude	40,000 ft
Shock	10G acceleration (11ms duration)
Vibration	10~300Hz 0.5G RMS random vibration

Standard Keyboard

n keyboard integrated with touchpad

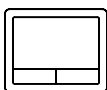
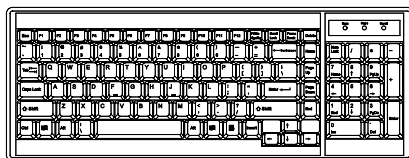

b keyboard integrated with trackball

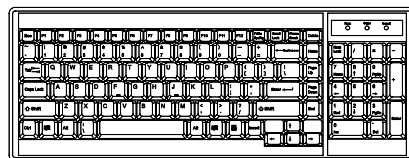

Supporting layouts

America		United States
EMEA		United Kingdom
		Germany
		France
		Spain
		Norway
Asia		Italy
		Russia
		Switzerland
		Netherlands
		Portugal
Asia		China
		Japan
		Korea
		Arabia
		Turkey

Keyboard Options

* US layout only

Mn Mac keyboard with touchpad



Sn SUN keyboard with touchpad

Mb Mac keyboard with trackball

Sb SUN keyboard with trackball



Nova 2U Rack Mount Dual Monitor KVM Console Drawer

Diagrams (mm)

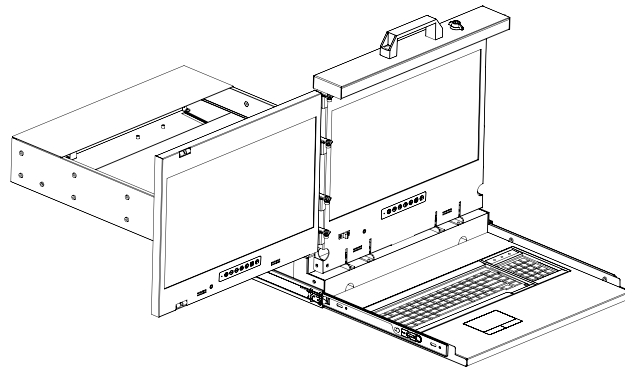

Front View

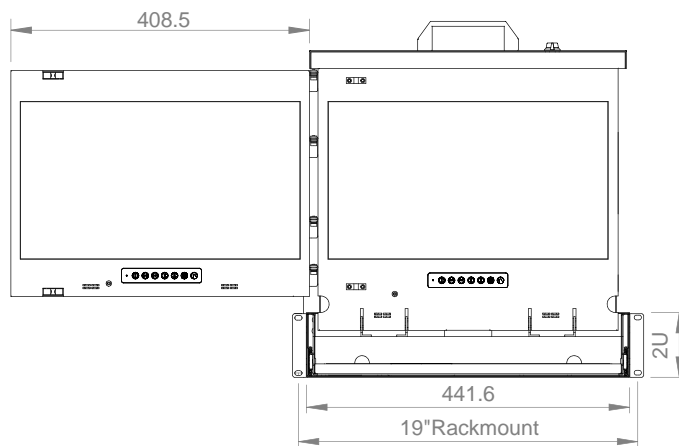

Side View

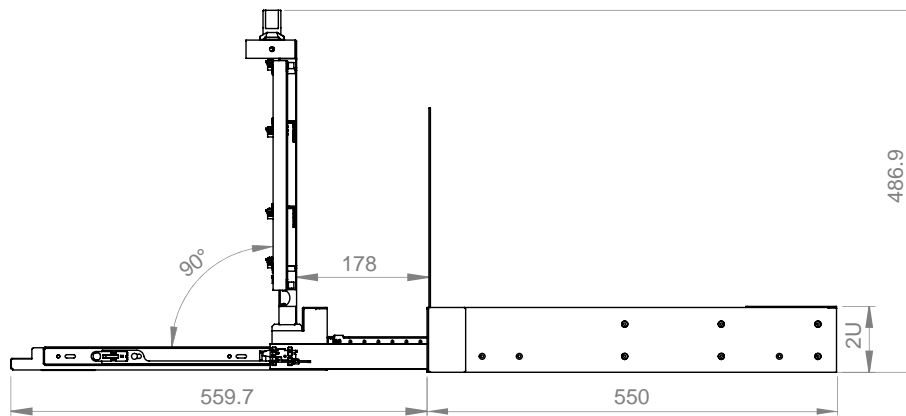

Top View

